

قالب های برش گام به گام طراحی و ساخت

فصل دوم: انواع قالب ها

ویرایش اول

زمستان ۹۳

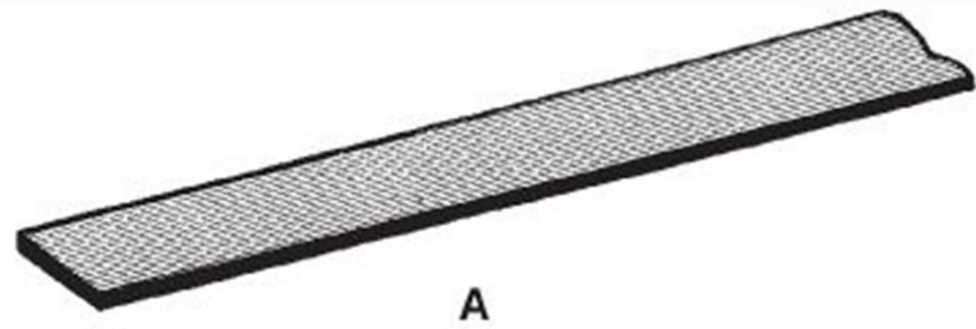

A

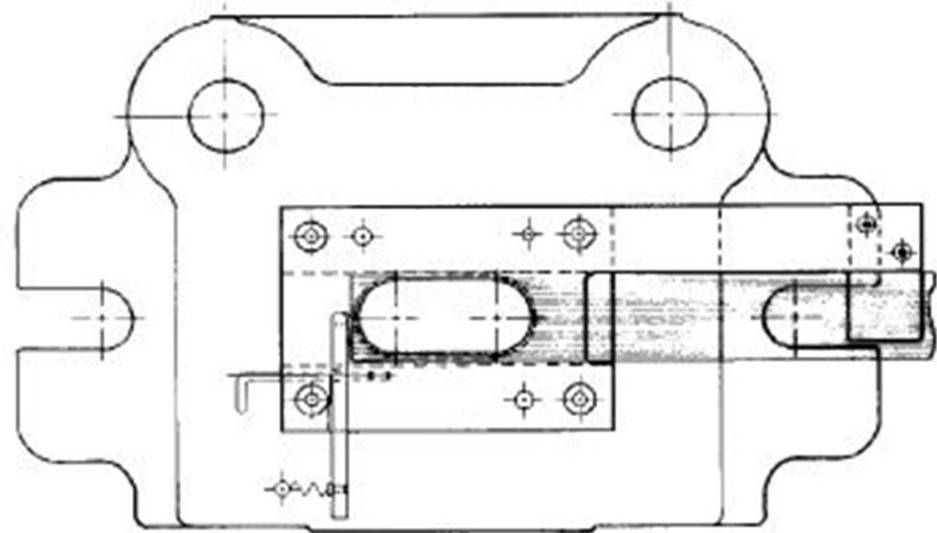

B

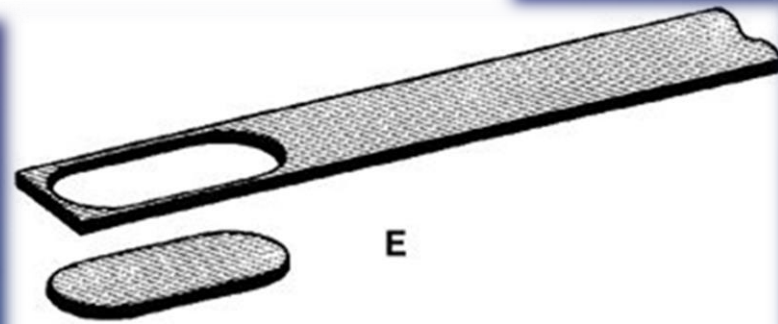

E

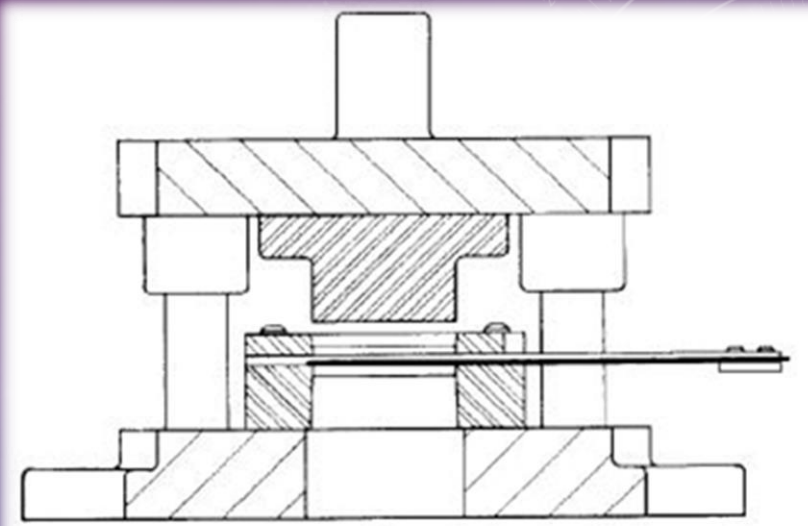

C

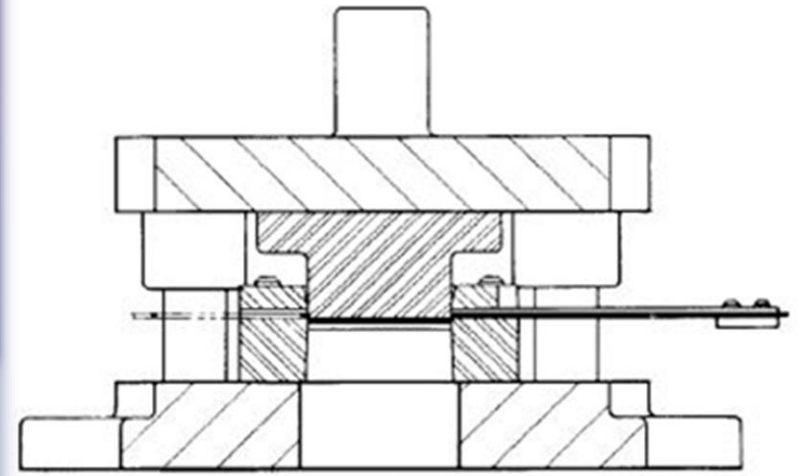

D

Figure 2.1 Blanking die.

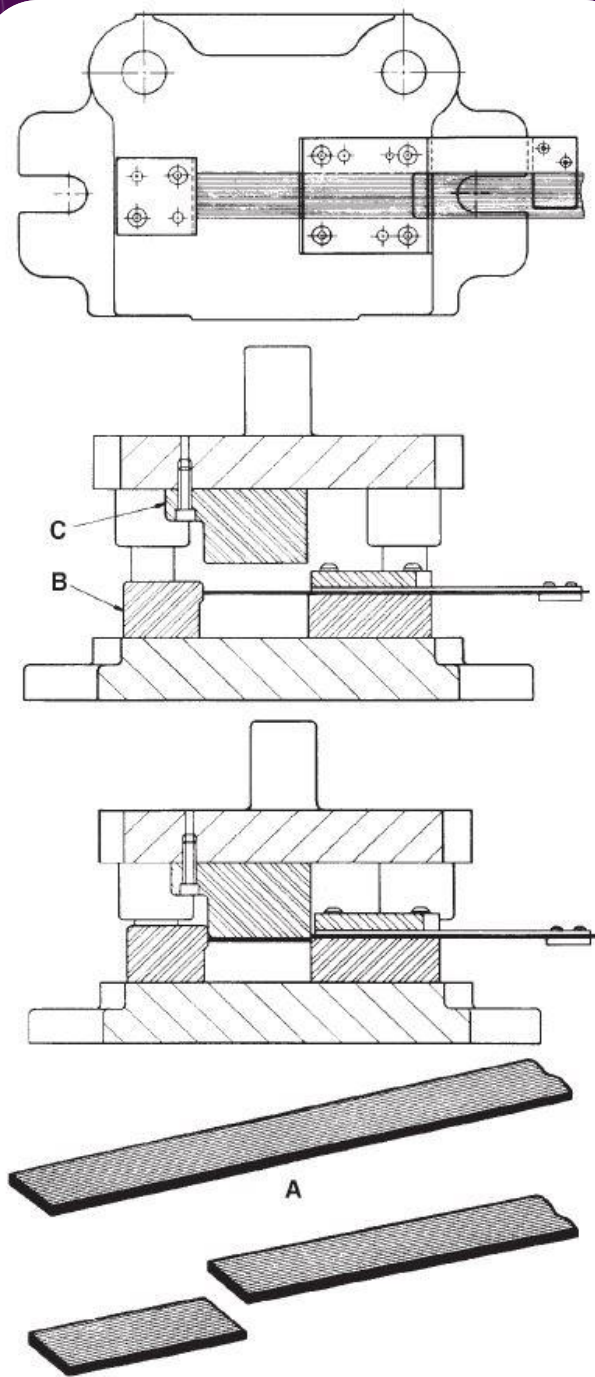

Figure 2.2 Cut-off die.

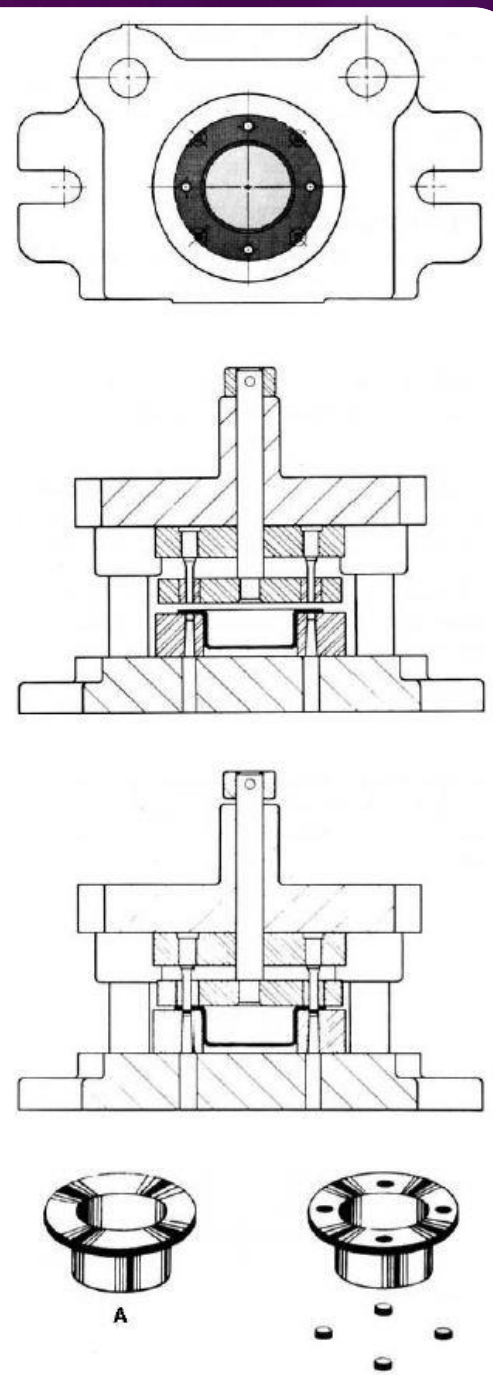

Figure 2.3 Piercing die.

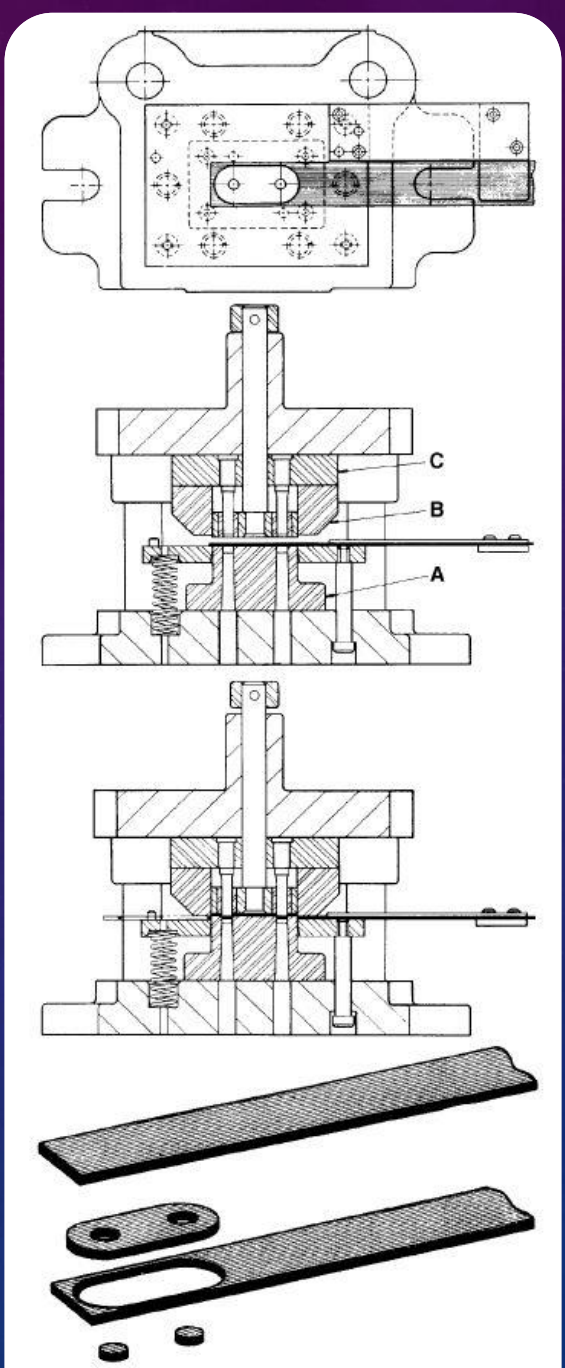

Figure 2.4 Compound die.

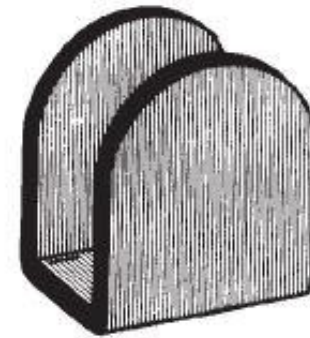
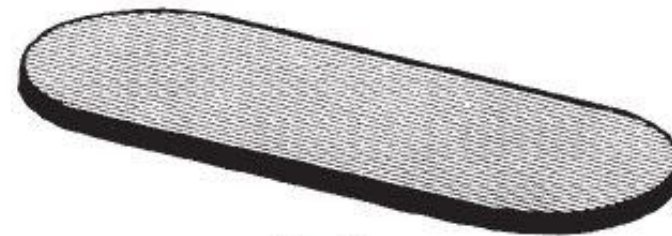
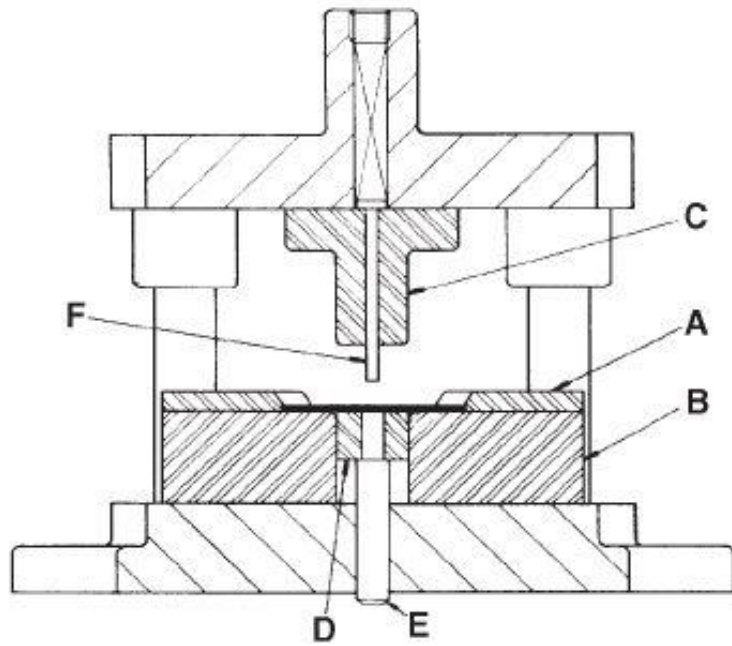
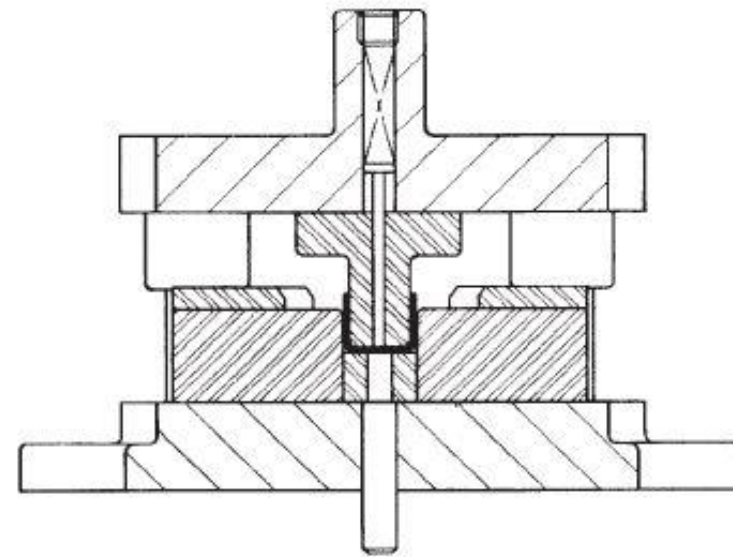
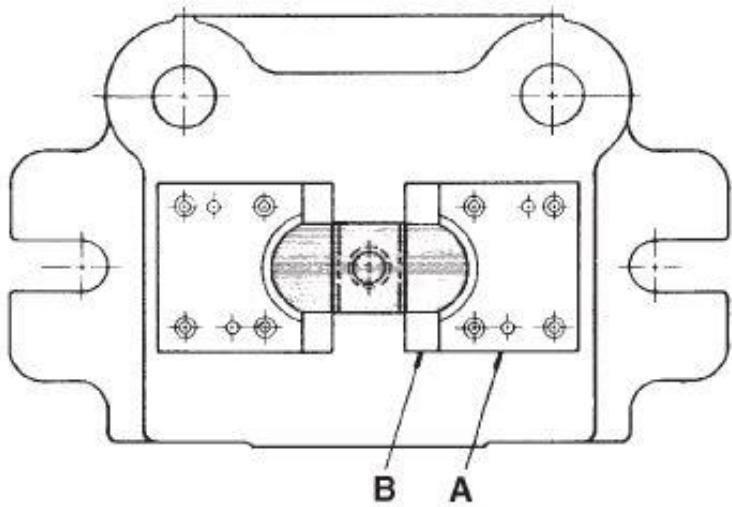

Figure 2.5 Bending die.

Figure 2.5 Bending die.

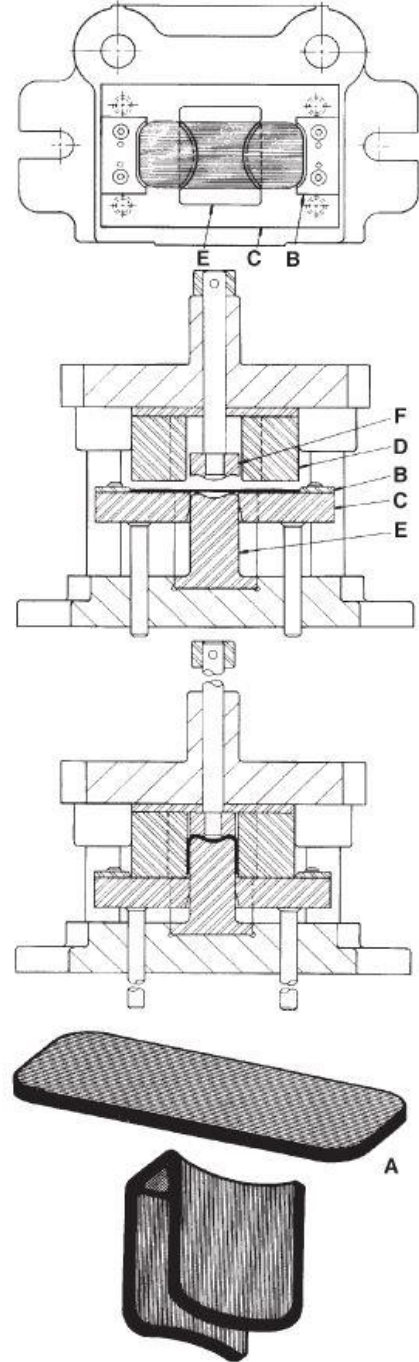

Figure 2.6 Forming die.

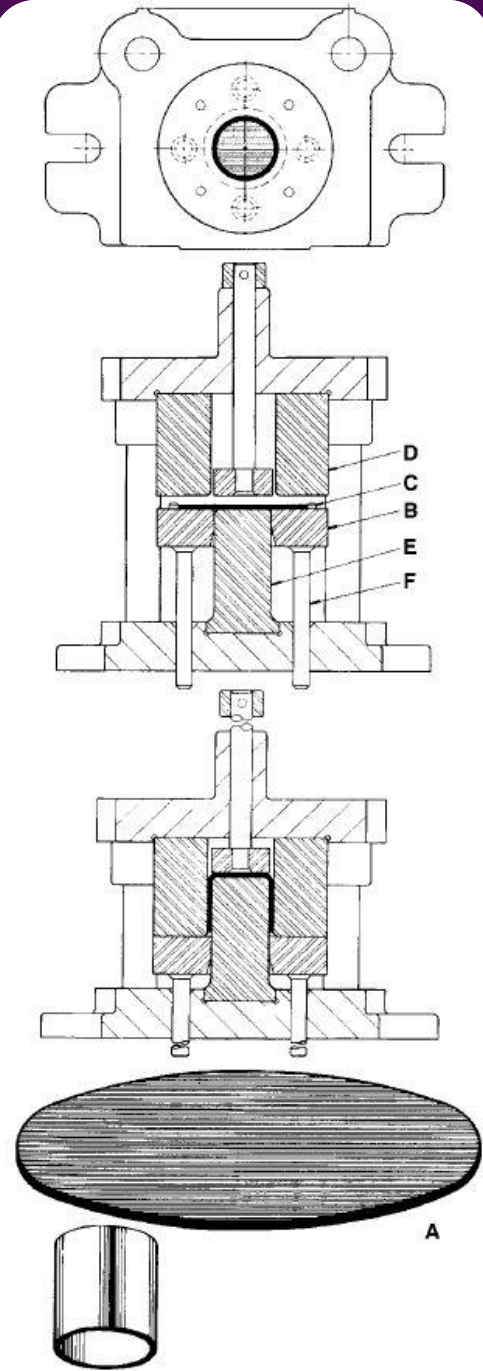

Figure 2.7 Drawing die.

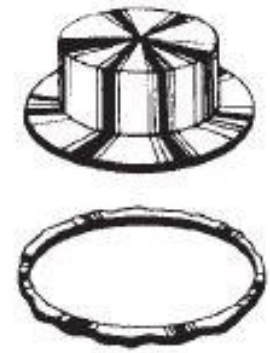
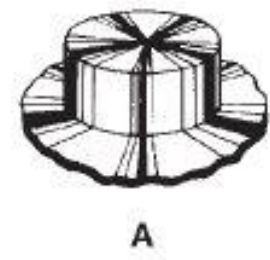
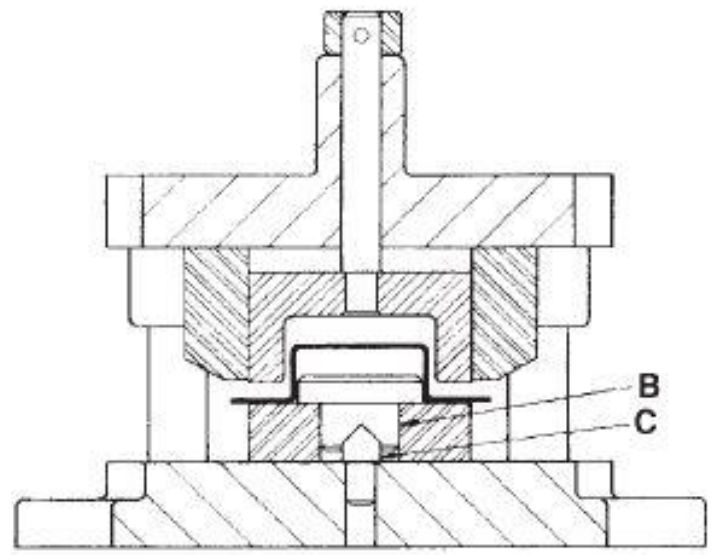
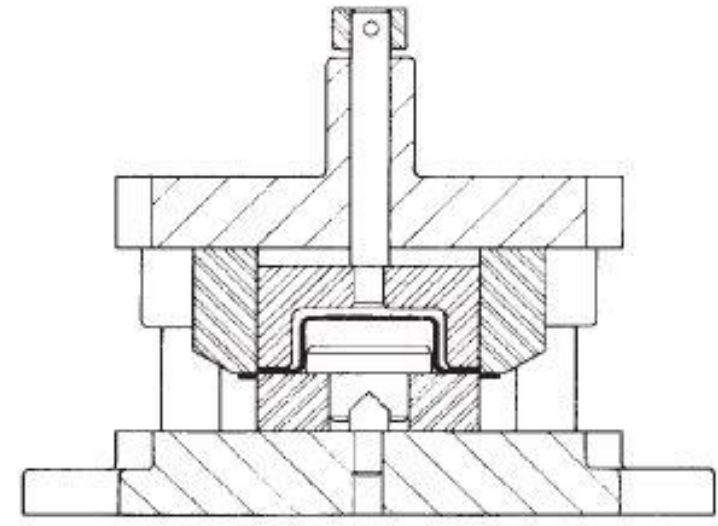
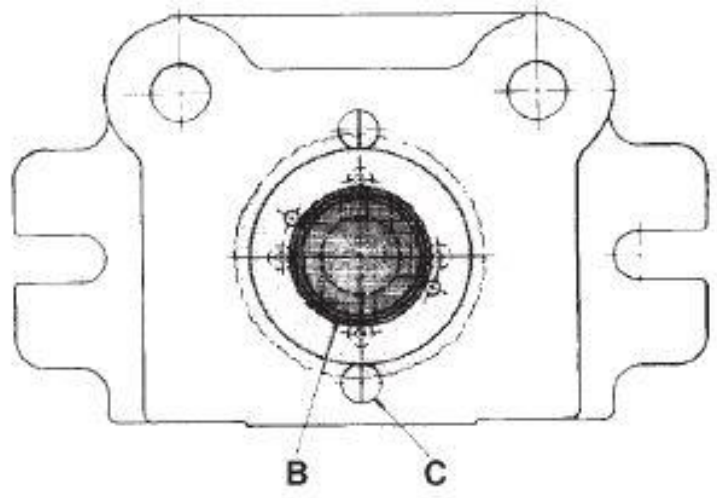

Figure 2.8 Trimming die.

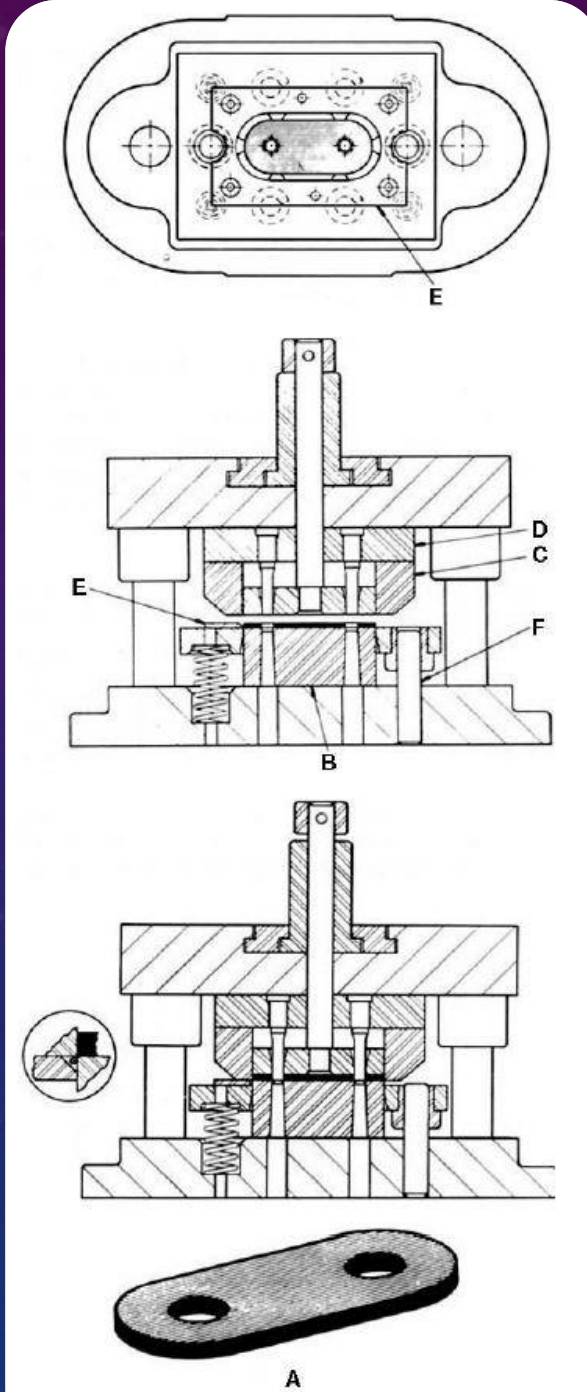

Figure 2.9 Shaving die.

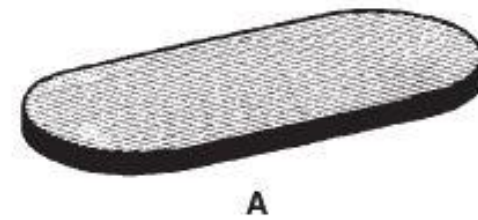
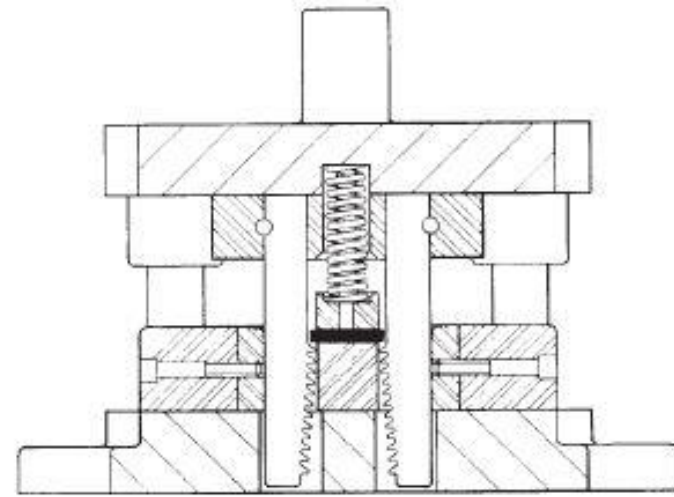
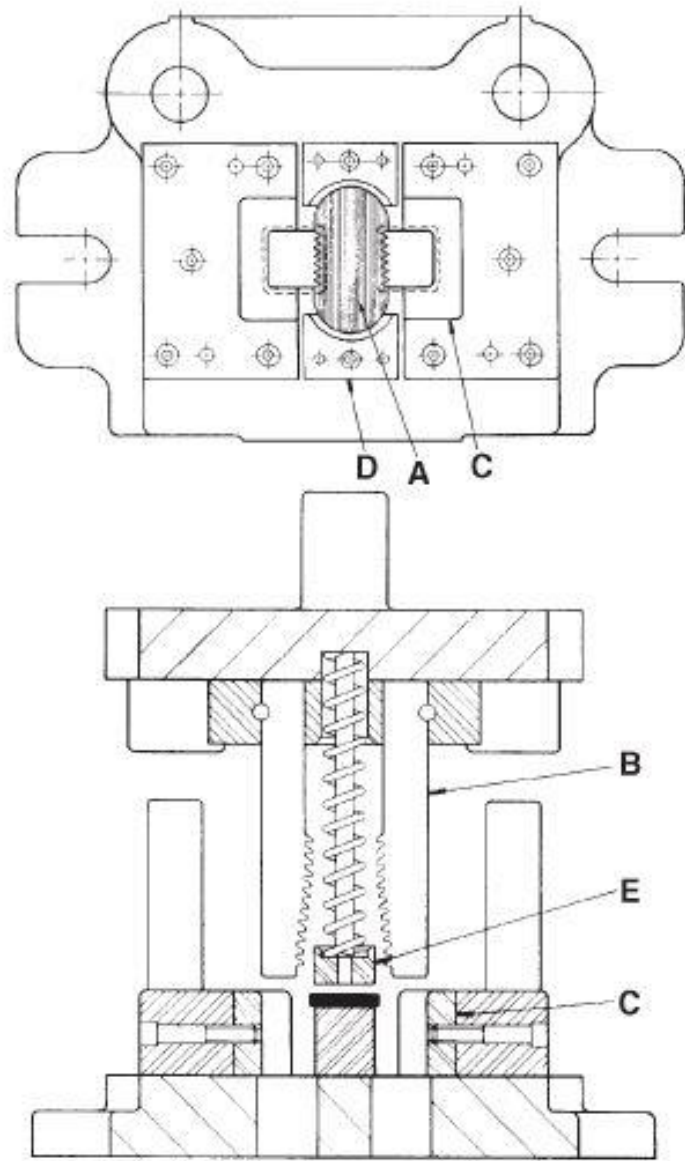

Figure 2.10 Broaching die.

Figure 2.10 Broaching die.

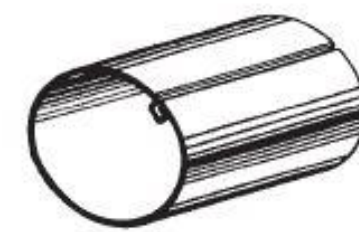
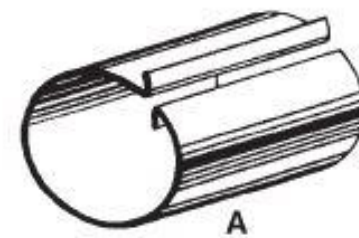
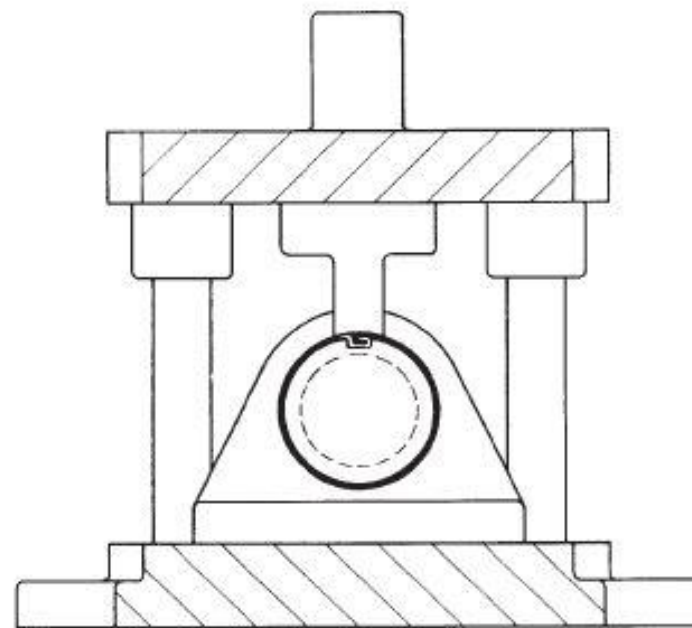
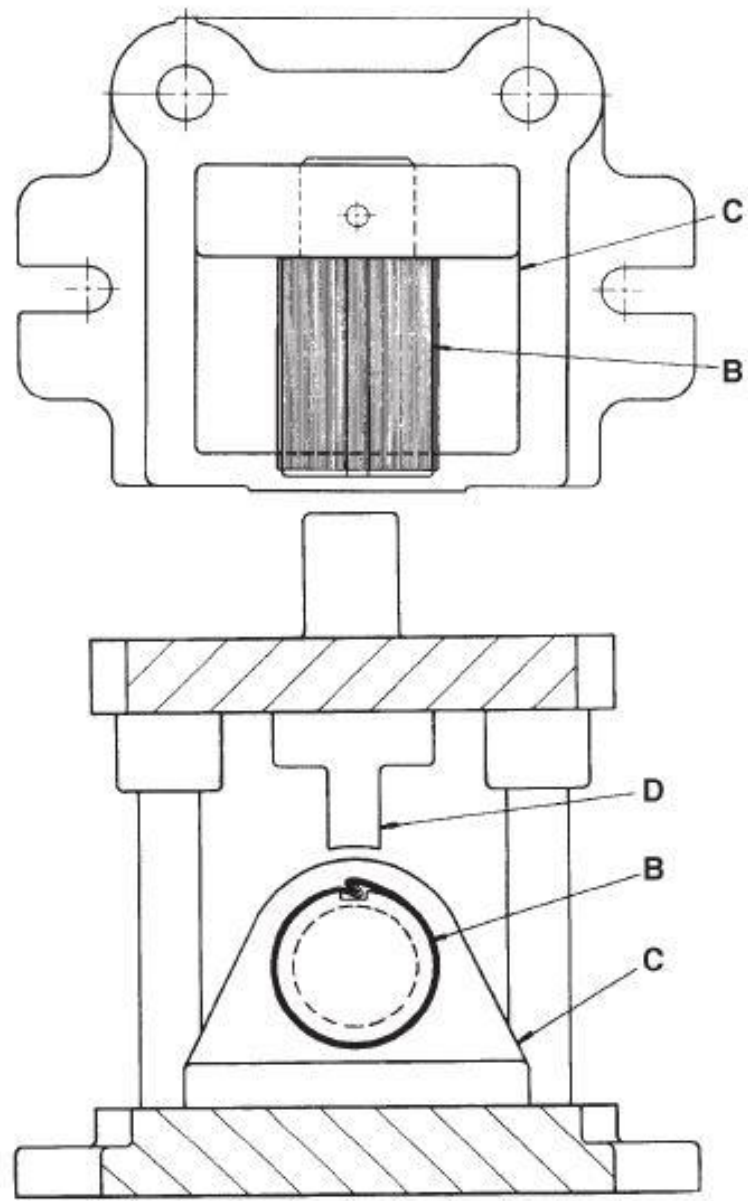

Figure 2.11 Horn die.

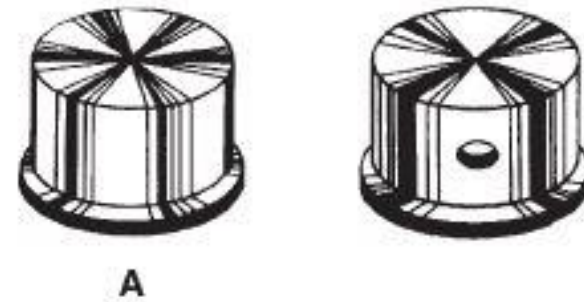
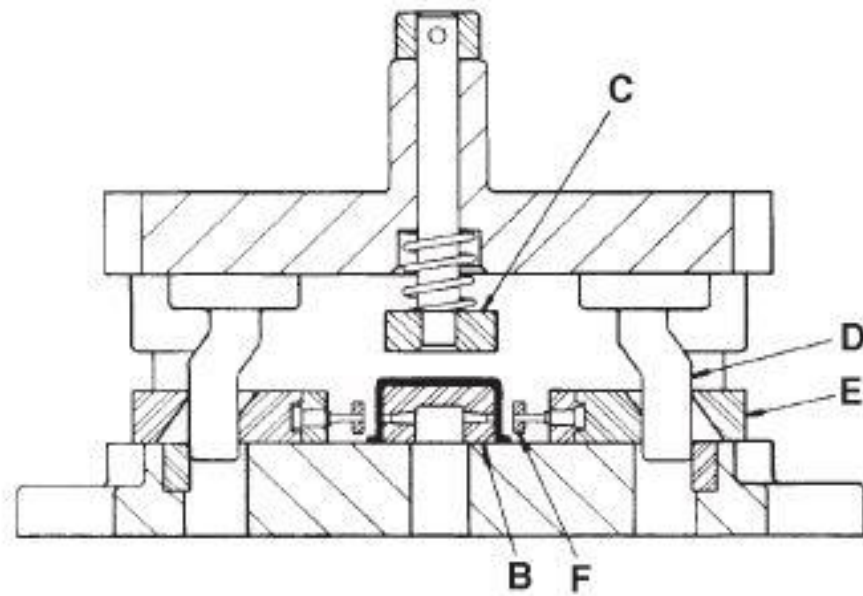
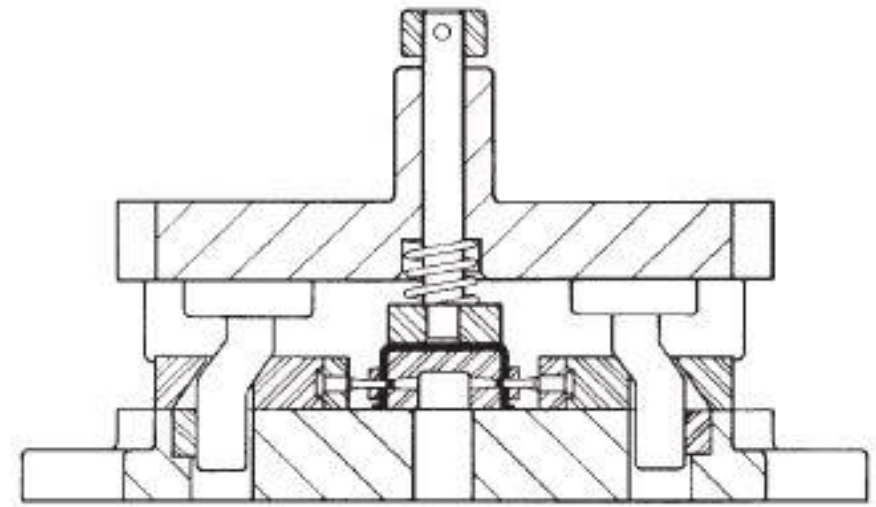
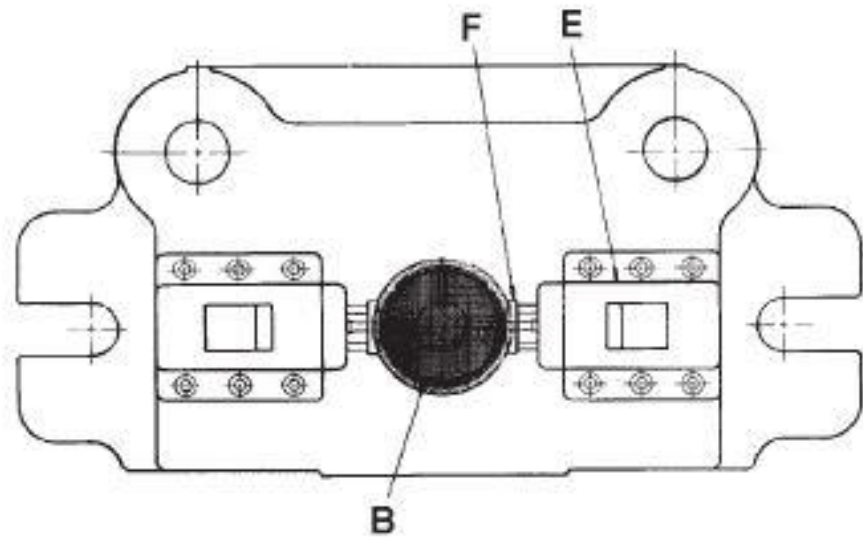

Figure 2.12 Side cam die.

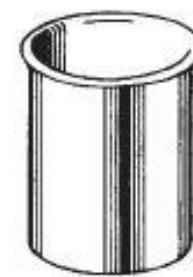
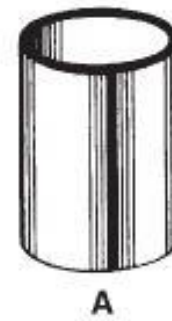
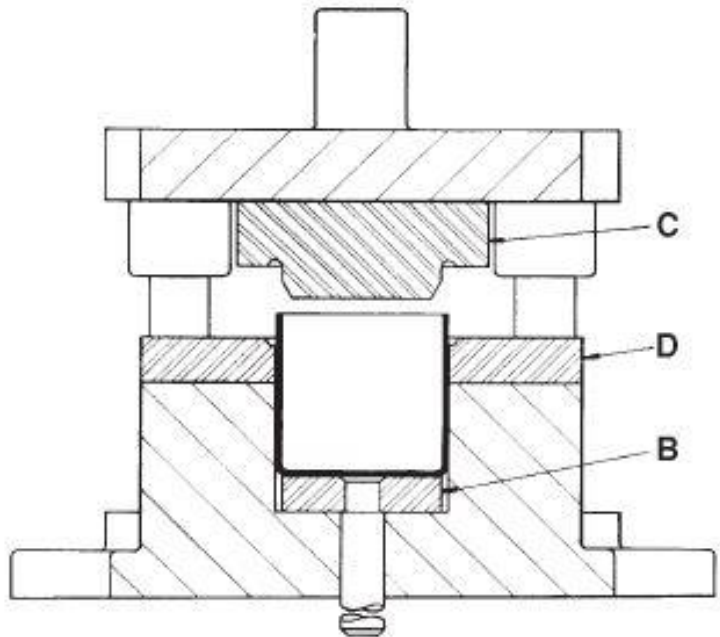
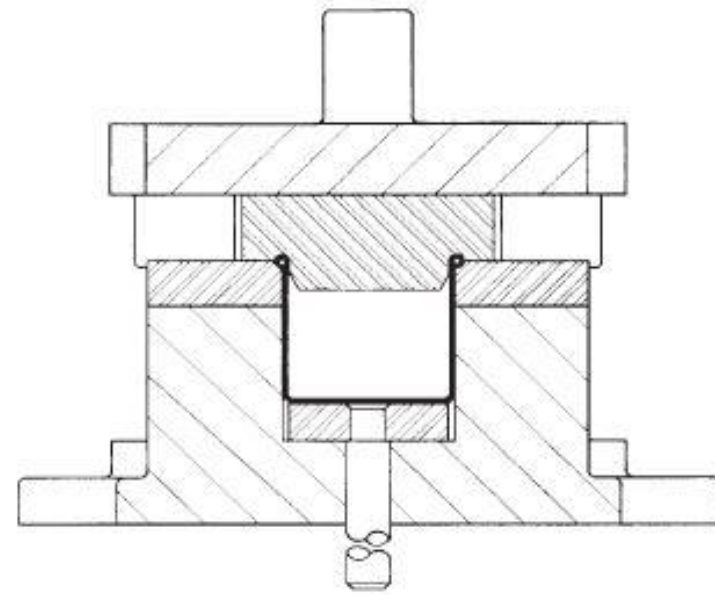
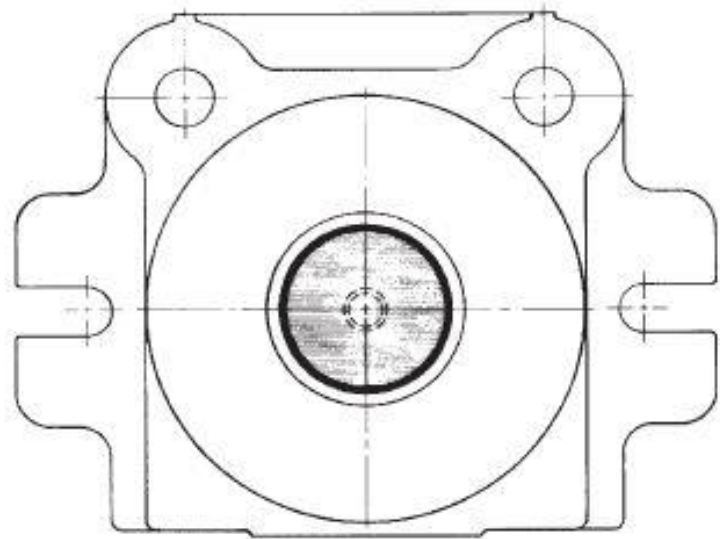

Figure 2.13 Curling die.

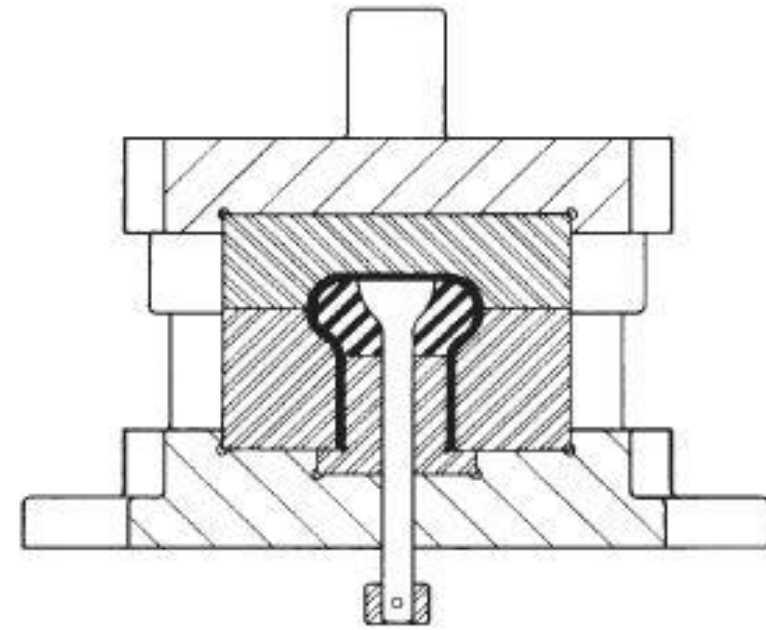
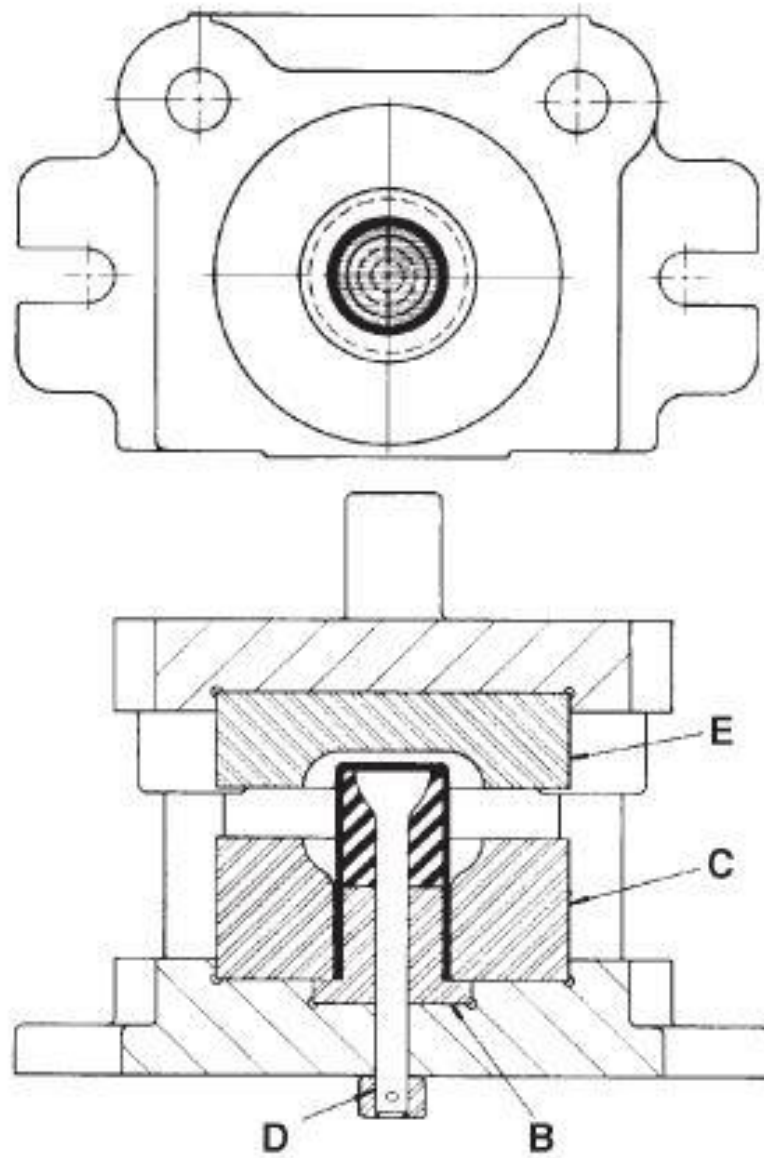

Figure 2.14 Bulging die that uses rubber as the bulging medium.

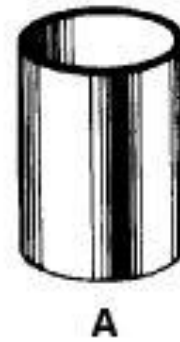
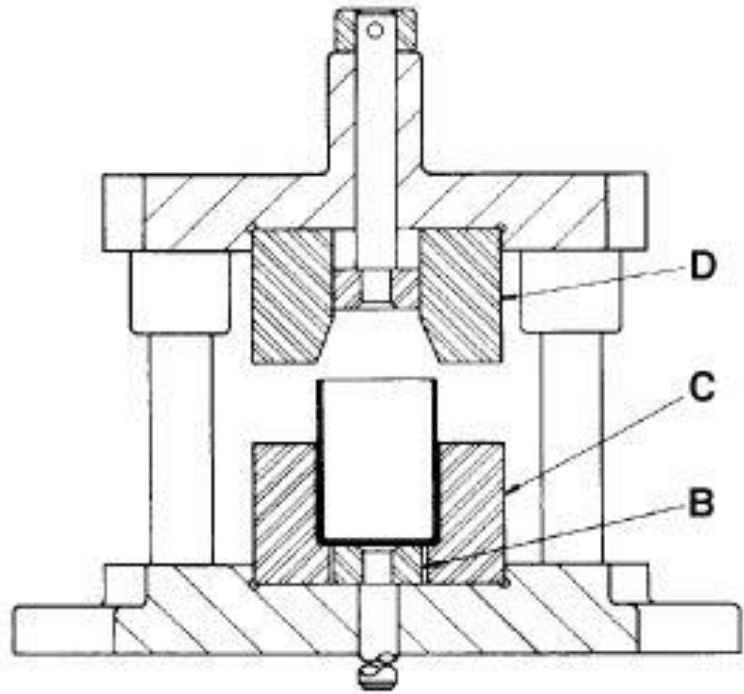
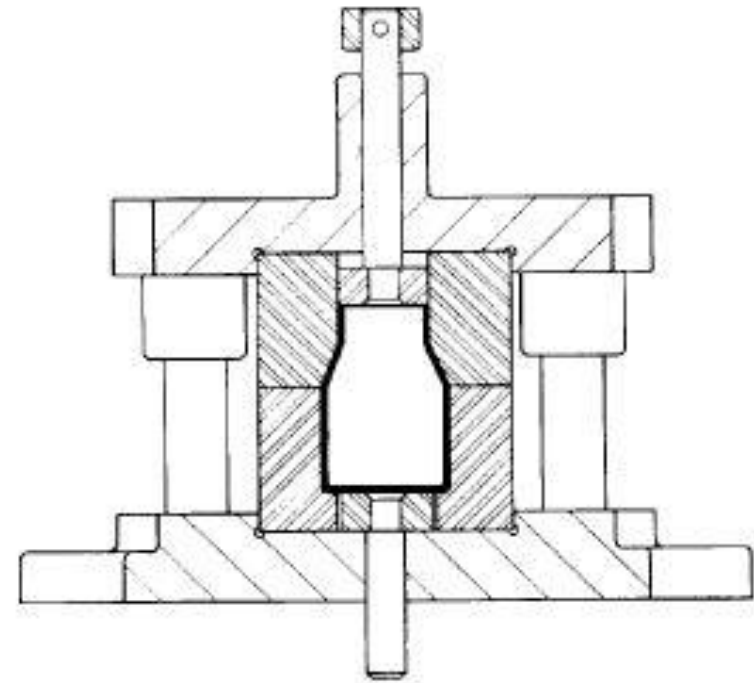
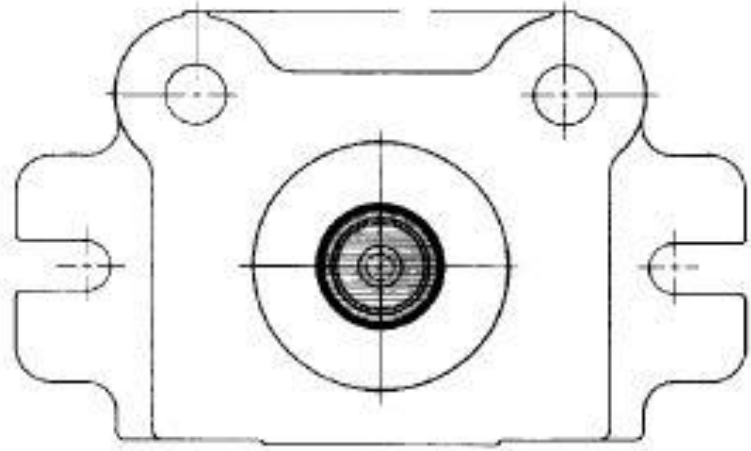
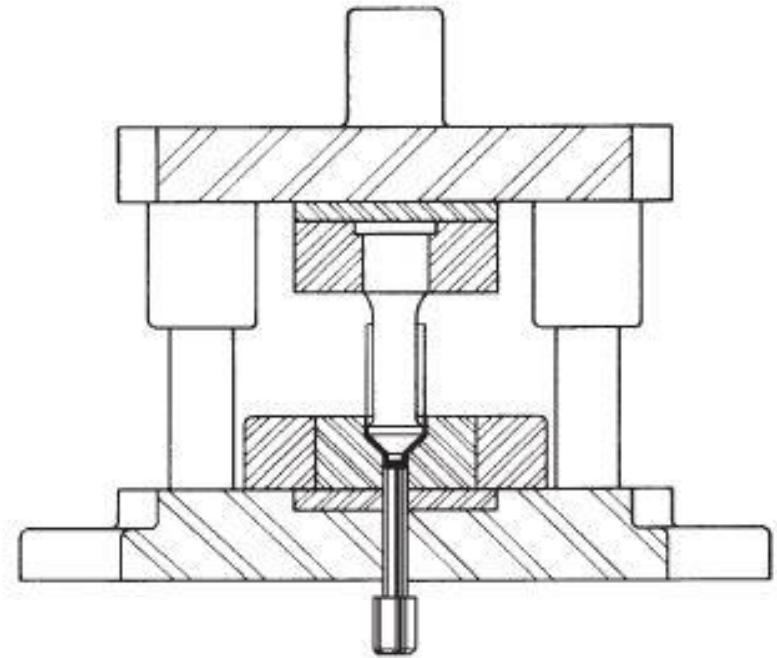
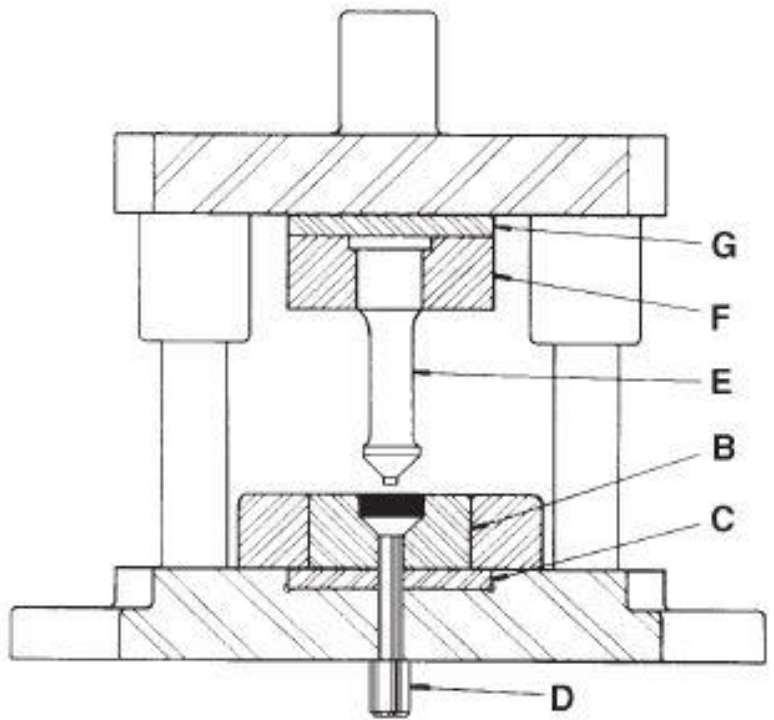
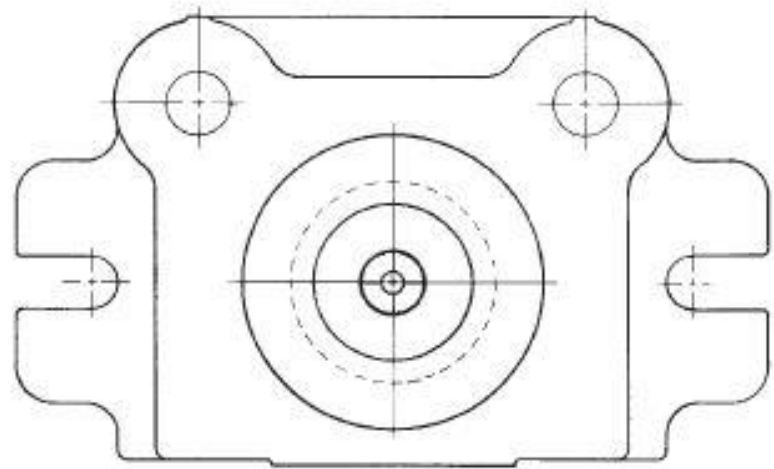

Figure 2.15 Swaging die.



A



Figure 2.16 Extruding die.

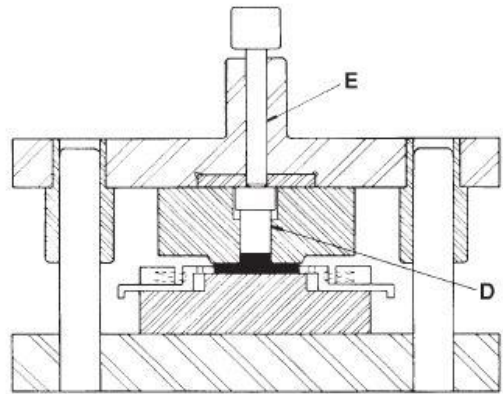
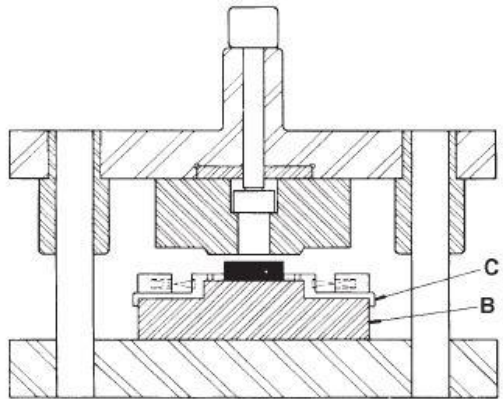
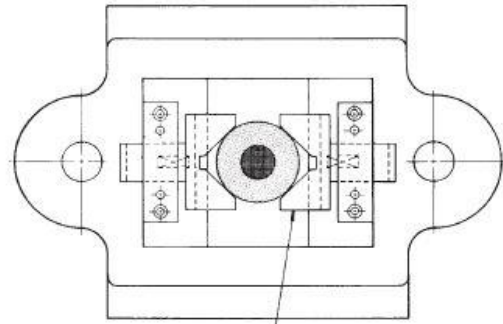

A

Figure 2.17 Cold coining die.

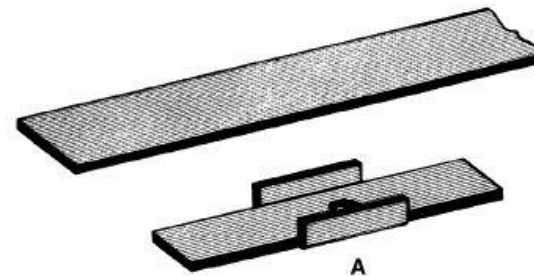
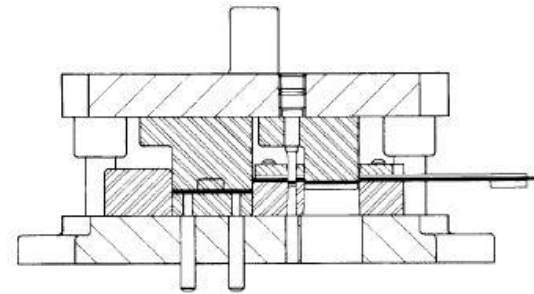
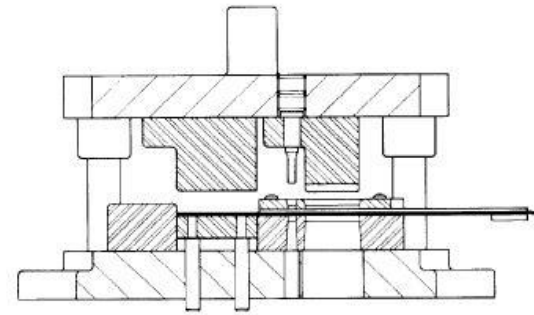
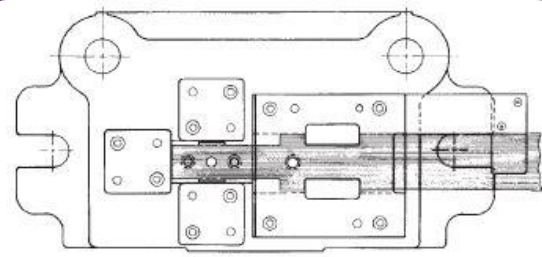

Figure 2.18 Progressive die.

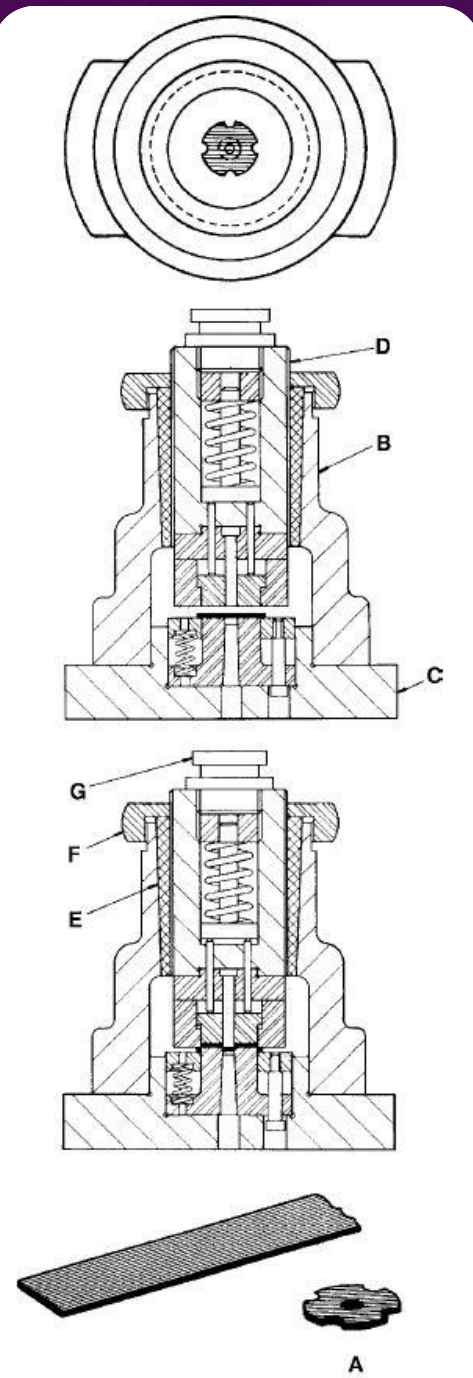

Figure 2.19 Sub-press die.

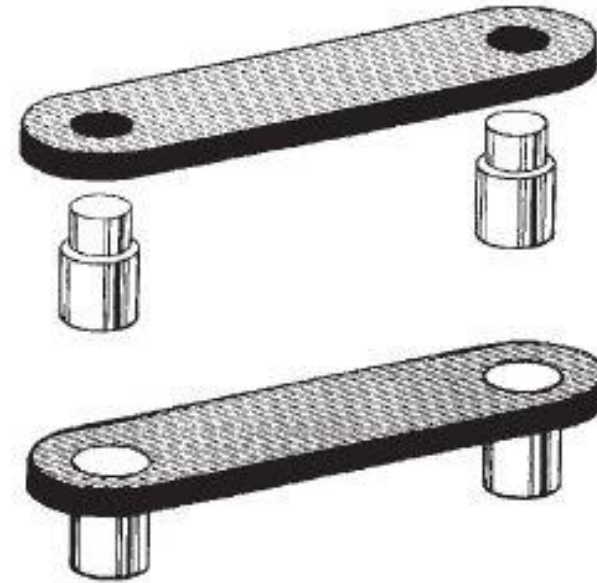
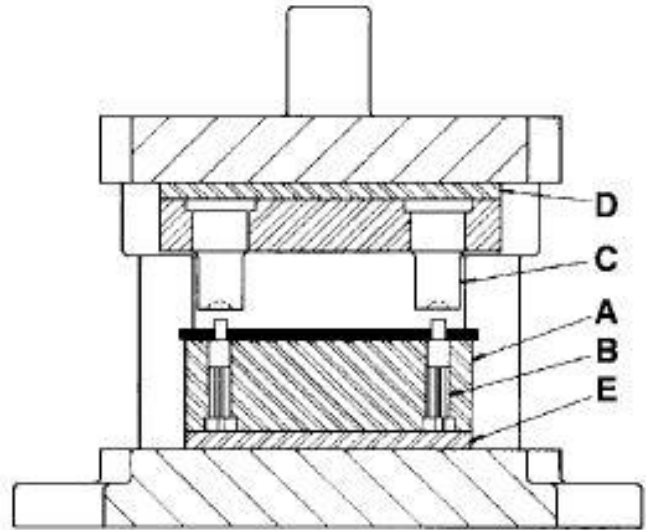
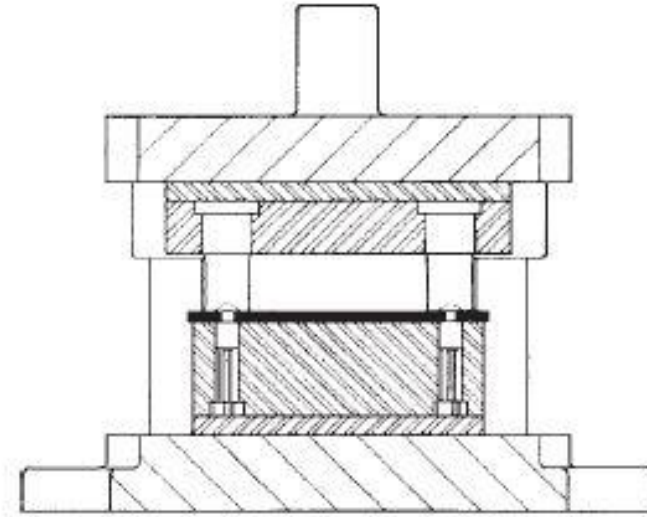
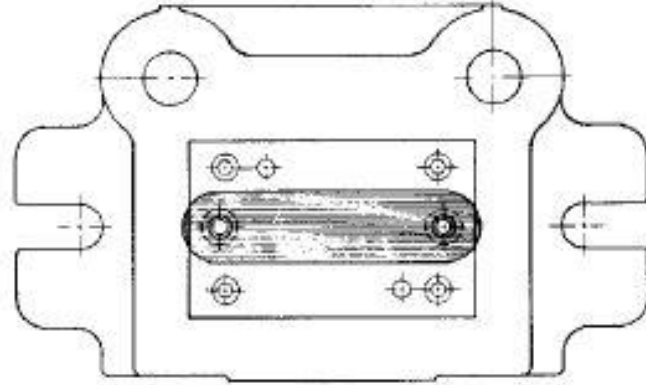

Figure 2.20 Assembly die.

پایان فصل دوم

با سپاس از توجه شما...